

ECLATE CRIC ISOLE MANUEL

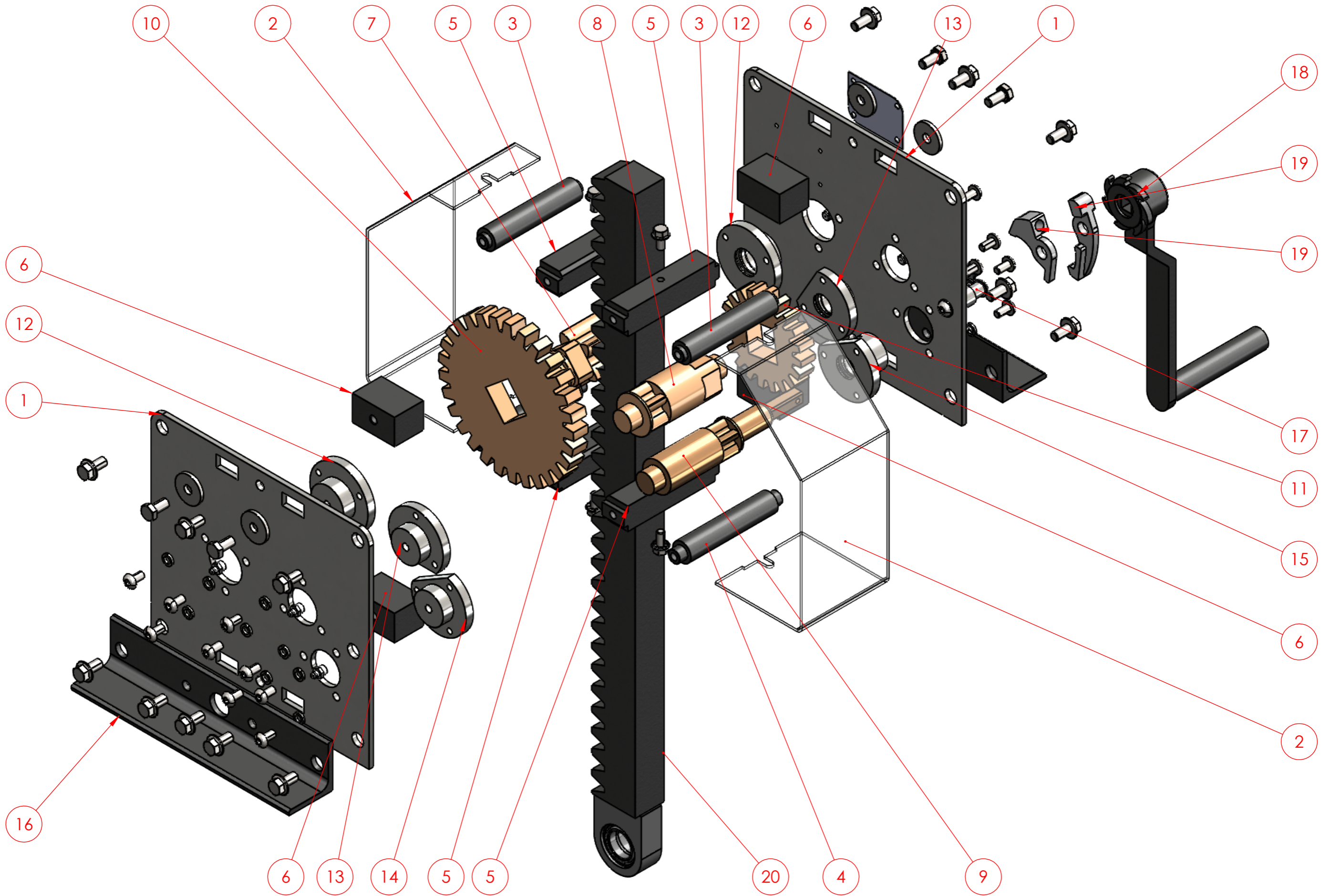

NOMENCLATURE

Rep	DESIGNATION	TYPE DE CRIC						
		F02	F04	F06	F08	F10	F12	F15
1	PLAQUE	F4001	F4004	F4006	F4008	F4010	F4012	F4014
2	CARTER	F4002	F4005	F4007	F4009	F4011	F4013	F4015
3	ENTRETOISE RONDE COURTE	F6001	F6004	F6007	F6007	F6011	F6011	F6014
4	ENTRETOISE RONDE LONGUE	F6002	F6005	F6008	F6010	F6012	F6012	F6015
5	ENTRETOISE DE GUIDAGE	F6003	F6006	F6009	F6009	F6013	F6013	F6016
6	BLOC DE GUIDAGE	F7002	F7004	F7006	F7006	F7008	F7008	F7012
7	NOIX CREMAILLERE	F2001	F2002	F2003	F2003	F2004	F2004	F2005
8	NOIX INTERMEDIAIRE	X	F1001	F1002	F1002	F1003	F1003	F1004/F1005
9	NOIX MANIVELLE	F0001	F0002	F0003	F0004	F0005	F0005	F0007
10	ROUE CREMAILLERE	F3001	F3002	F3004	F3005	F3007	F3008	F3008
11	ROUE INTERMEDIAIRE	X	F3003	F3001	F3001	F3006	F3006	F3002/F3009/F3010
12	PALIER CREMAILLERE	F5001	F5003	F5004	F5004	F5005	F5005	F5006
13	PALIER INTERMEDIAIRE	X	F5001	F5003	F5003	F5004	F5004	F5003/F5004
14	PALIER MANIVELLE COURT	F5001	F5001	F5001	F5001	F5001	F5001	F5001
15	PALIER MANIVELLE LONG	F5002	F5002	F5002	F5002	F5002	F5002	F5002
16	CORNIERE	F7001	F7003	F7005	F7007	F7009	F7010	F7011
17	AXE DE CLIQUET	F7019	F7019	F7019	F7020	F7020	F7020	F7014
18	MANIVELLE DE SECURITE	G0002	G0002	G0002	G0048	G0048	G0048	G0048
19	CLIQUET DOUBLE AVEC RESSORT	F-SPK250-000-0000	F-SPK250-000-0000	F-SPK250-000-0000	F-SPK300-000-0000	F-SPK300-000-0000	F-SPK300-000-0000	F-SPK300-000-0000
20	CREMAILLERE	50x30 module 6	60x40 module 8	80x50 module 10	80x50 module 10	90x60 module 12	90x60 module 12	100x60 module 14